

Rail replacement as a maintenance benchmark

Bernhard Klee

All over the world the transport of people by rail is on the increase. Local as well as regional and long-distance transport record a continuous rise in passenger numbers with an unforeseeable potential for growth, especially in conurbations. The drivers behind this are the road traffic situation - overload of the public road space, lack of sufficient car parking and an increase in pollution levels - as well as the change in demographics. The increased maintenance requirement resulting from this and the decrease in possessions pose unprecedented challenges to infrastructure operators.

As part of its "Construction initiative 2017", Deutsche Bahn (DB) is investing 7.5 billion Euro in the German rail network, pushing the complete renewal and upgrade of the German line network [1]. At peak times this means 850 work sites per day - work on the infrastructure, especially preventive maintenance, has to become faster and work sites more predictable for highly frequented sections of line to remain available safely.

Flexible, modular rail replacement systems allow railway construction companies to carry out all the logistics and work site management with their own machine fleet, on time:

- Precise provision of means of transport, material and equipment
- Consistently high rail quality from the rolling mill to the work site
- Unloading according to regulations and at reliable process speeds
- Repositioning of rails for direct re-use
- Expert loading of old rails for recycling

Depending on the area of use and the task in hand - new construction or repair, targeted repair or complete rail replacement, high-speed lines or urban environment - the system requirements vary. With its product portfolio, ROBEL covers the whole range of rail loading systems, from manually operated rail loaders to automatic rail changeover on high speed lines. Over 50 years' experience since the delivery of our first rail loading train to DB in 1964 form the basis of our know-how in design, manufacturing and maintenance of machines for rail transport, developed to customer-specific requirements, refined and updated over the years in co-operation with our customers.

1 The quality factor: risks in the rail loading process

Incorrect manipulation of rails, e.g. non-adherence to bending limits during loading and unloading, may result in rail faults, such as deformation and distortion. Not all rail faults can be established with visual or non-destructive testing methods. If faults remain undetected, this may result in rail breaks in the worst case and consequently in lengthy and cost-intensive failure analysis investigations [2].

If a rail is unloaded without the appropriate equipment, the rail pulled onto the track without guidance can easily tip on its side. In this position it will be stressed beyond its yield point. Furthermore, this will result in vibrations that will intensify the rate of the permanent deformations (Fig. 1) [3]. The geometric surface defects occurring in this case may not be detected until the track acceptance and can then hardly be distinguished from any manufacturing faults, making it more difficult to clearly settle any warranty issues with the rolling mill and welding works as well the construction company.

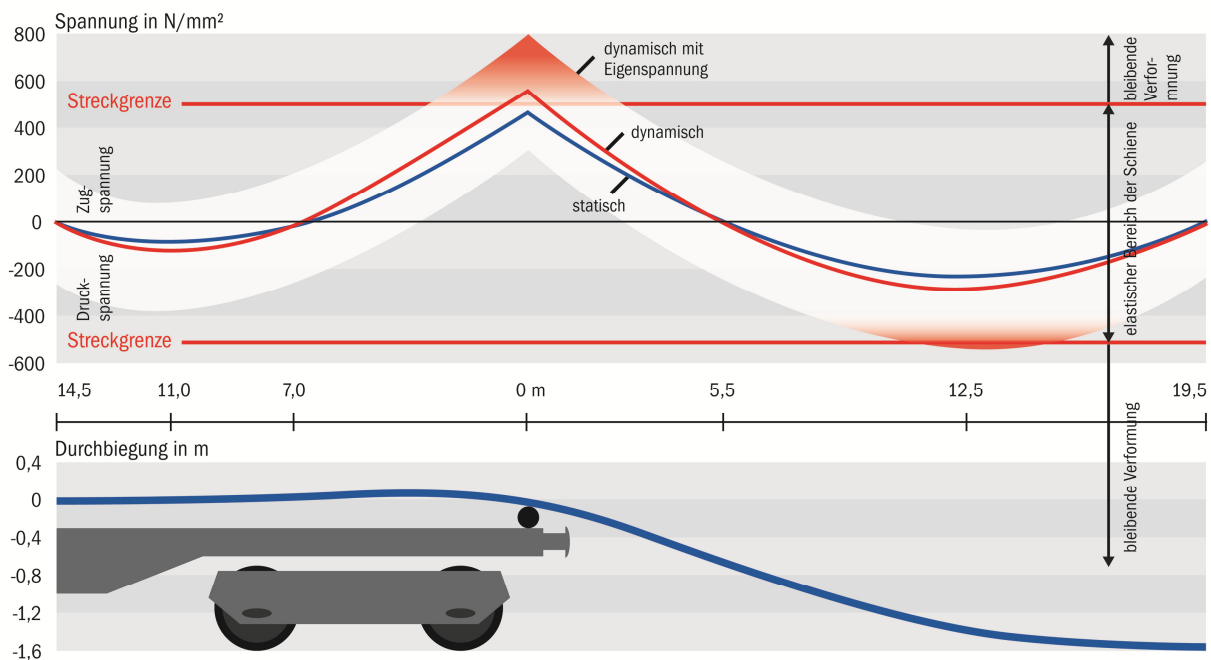

Fig. 1: Exceeding the yield point when unloading rails incorrectly Source DB/Work procedures for permanent way maintenance

Using proven and approved unloading systems for damage-free transport and unloading ensures that the quality requirements of the rail process chain are adhered to. The decision on which system is used and which new machine is invested in needs to be made by the maintenance company based on the frequency of use, the length of the rail sections to be renewed and the requirements of the work process (Table 1).

| Type of machine | Machine number | Rail length | Typical work site length | Optional level of automation depending on design | Unloading position | Replacement of closure rails | Urban | Main line track | Loading |
|-----------------|----------------|--------------------|--|--|--------------------|------------------------------|---------|-----------------|---------|
| Rail Putler | 40.30 | up to 180m | several hundred metres to several kilometres | low to medium | flexible | no | limited | yes | no |
| Rail Loader | 40.44 | approx. 10 to 120m | approx. 10 to 120m | low to high | only outside | yes | yes | yes | yes |
| REXS | 40.61-65 | approx. 60 to 500m | approx. 120m to several kilometres | low to very high | flexible | no | yes | yes | yes |
| MMS | 69.70 | up to 15m | targeted | very high | flexible | yes | yes | yes | yes |

Table 1: Overview of ROBEL rail transport and replacement systems

2 The flexibility factor: Rail Loader 40.44

Due to ever shorter possessions, the challenge for the manipulation of rails with a length of up to 120 metres is to load as many rails as possible within the given conditions, such as load profile and permitted weight, and to unload them as quickly and safely as possible while adhering to the bending limits and yield points.

The 40.44 Rail Loader (Fig. 2) is available at different levels of automation: from a completely manually operated design without power supply (Fig. 3) through to a fully electrically driven all-rounder which allows rails of different lengths to be loaded and unloaded within a very short time on both sides. An optional movable weight maximises flexibility with regard to the permitted weight distribution.

The cranes are installed via variable mounting options, such as stop chains or clamping devices on standard flat wagons or container wagons. Depending on the requirement, the crane can be positioned on the side for maximum loading capacity or in the centre for more flexible working on both sides. Side mounting also has the benefit that the rail loader can also be mounted on a wagon that is already loaded with rails by pushing the frame under the rails. This allows for the wagons to be loaded in any location.



Fig. 2: Flexible mounting of loading cranes as well as optional automation levels make the 40.44 Rail Loader a genuine all-rounder with a high safety factor.

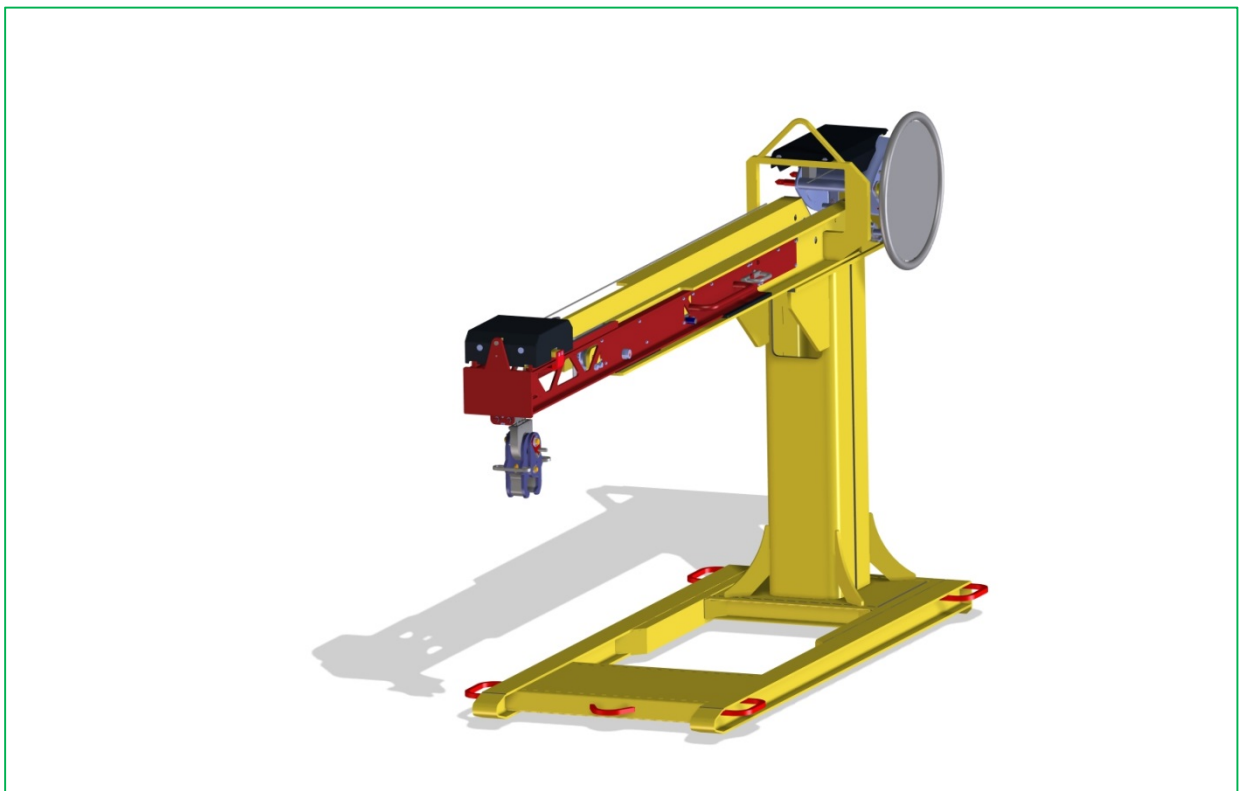

Fig. 3: The manual crane system can be mounted quickly on all common standard flat wagons and is designed for 900 to 1500 kg lifting capacity.

To avoid inadmissible deformations, we recommend using a crane unit for every ten metres of rail length.

Optional, remote-controlled rail tongs grab the rails and put them down - both processes are fully automated. The operator remains outside of the danger zone, considerably reducing the risk of injury (especially from contusions). The electric travelling crab is positioned via a rack-and-pinion drive precisely, safely and synchronously up to a superelevation of 180 mm and pushes the outrigger to the desired length. In contrast to a friction drive, the travelling crab will not slip, even in adverse weather such as humidity, there is no longer the need for the laborious levelling of the outriggers.

The length of the fixed and telescopic part of the outrigger is manufactured dependent on existing profile requirements (e.g. in a tunnel). Automatically extending outriggers make it possible to set different working modes. For instance, in “tunnel mode” the outrigger can be extended to a maximum of the predefined length within a profile, damage to the tunnel walls from fast and uncontrolled guidance are a thing of the past.

40.44 Rail Loaders are not only supplied as individual machines for mounting on flat or container wagons, they also can be deployed as a state-of-the-art modular complete system including wagon, independent power supply and a transport lock.

3 The sustainability factor: hybrid technology

At iaef 2017 ROBEL presented a prototype of a rail loading system with a hybrid drive for the first time (Fig. 4). The “Hybrid Power Pack” copes with peak currents during the run-in phase of the generator by drawing from a storage medium (Supercap). As the size of the generator is usually designed according to this peak current requirement, the new system allows a much smaller generator to be used that will continuously work at its optimum. Fuel consumption, exhaust gas and noise emissions are reduced significantly. Furthermore, the compact design improves maintenance safety and the service life of the generator.



Fig. 4: The Hybrid Power Pack optimises generator output and so reduces fuel consumption and emissions.

4 The modularity factor: 40.30 Rail Unloading Device

For companies that only work as service provider for rail logistics from time to time, the so-called “Rail Putler” (Fig. 5) is a cost-effective alternative to the Rail Train.



Fig. 5: The 40.30 Rail Putler is a cost-efficient alternative to the Rail Train.

The rail transport unit with the front-coupled rail unloading device is shunted with the rail joint end of the load to the start of the work site and the unloading belts are attached at the track via clamp heads. A shunting locomotive pulls the unit out from under the rails, which are retained by unloading belts and rail anchors, in working direction. A halt is made once the first pair of rails has passed both support blocks of the rail unloader, so that the rails can be secured in the rail guide heads. After that the load can be fully removed. All the remaining rails are gradually bound together with connecting straps and removed with the aid of a hydraulic rail puller.

Depending on the time window, rail length and local conditions, the combination of different systems will often offer the ideal solution: While the 40.44 Rail Loader will typically load and unload rails of around 40 metres in length laterally, the use of the connecting straps (Fig. 6) in combination with the Rail Putler allows the unloading of these connected rails in longitudinal direction without causing any damage.

ROBEL offers a modular design for all rail loading systems, made possible by container frame mounting. This avoids an unnecessary intervention into the structure of the wagon, the wagon approval is unaffected. Another benefit is the flexibility gained with regard to the use of the wagons. The independent hydraulic supply of each transport wagon allows for an easy extension of the system and increases availability.



Fig. 6: The use of connecting straps makes it possible to unload rails in longitudinal direction without causing any damage.

5 The time factor: replacement of closure rails

For targeted interventions on localised rail faults in small time windows the Mobile Maintenance System (MMS) can be used. The MMS, consisting of the Mobile Maintenance Unit, Intermediate Car and Traction and Supply Unit, is a self-sufficient workshop on wheels - the entire maintenance can be done in one logistics and work process. Crew, machines and materials are transported to the work site within the system and have direct access to the track. Maintenance work, such as the replacement of rails, individual sleepers and rail fastenings as well as corrections of the track geometry and thermit welding are carried out in a well-lit, safe environment, protected from the weather and trains on the adjacent track. Furthermore, the system allows work to be carried out on live overhead line systems and with the adjacent track open for traffic.

One of the central tasks of the MMS is the replacement of closure rails. From underfloor storage of up to six rails of 15 metres length maximum to the customised extraction system, all components are designed for maximum operational safety and ergonomics. Petrol-driven machines are no longer used, cutting equipment is replaced with band saws to avoid sparks and fumes.

A tandem chain hoist transports the rails from the storage area to the work area, minimising the risk of injuries. Hydraulically operated equipment is used for cutting, stressing, grinding and ballast consolidation, with power supplied from side wall connections (Fig. 7).

According to the British network operator Network Rail, who has had a total of eight MMS systems in operation since 2016 in the South of England, the cost of rail replacement has halved due to time savings and an increase in work quality.

6 The safety factor: REX-S Rail Train

As part of continuous renewal of longer sections of lines that cannot be re-profiled, rail trains are used for the transport of long-welded rails of up to 500 m.

The REX-S Rail Train (Fig. 8) consists of three parts: The **Rail Manipulator (RM)** is responsible for loading and unloading the rails on the transport unit. Equipped with an independent hydrostatic drive the manipulator moves on its own rails over the whole

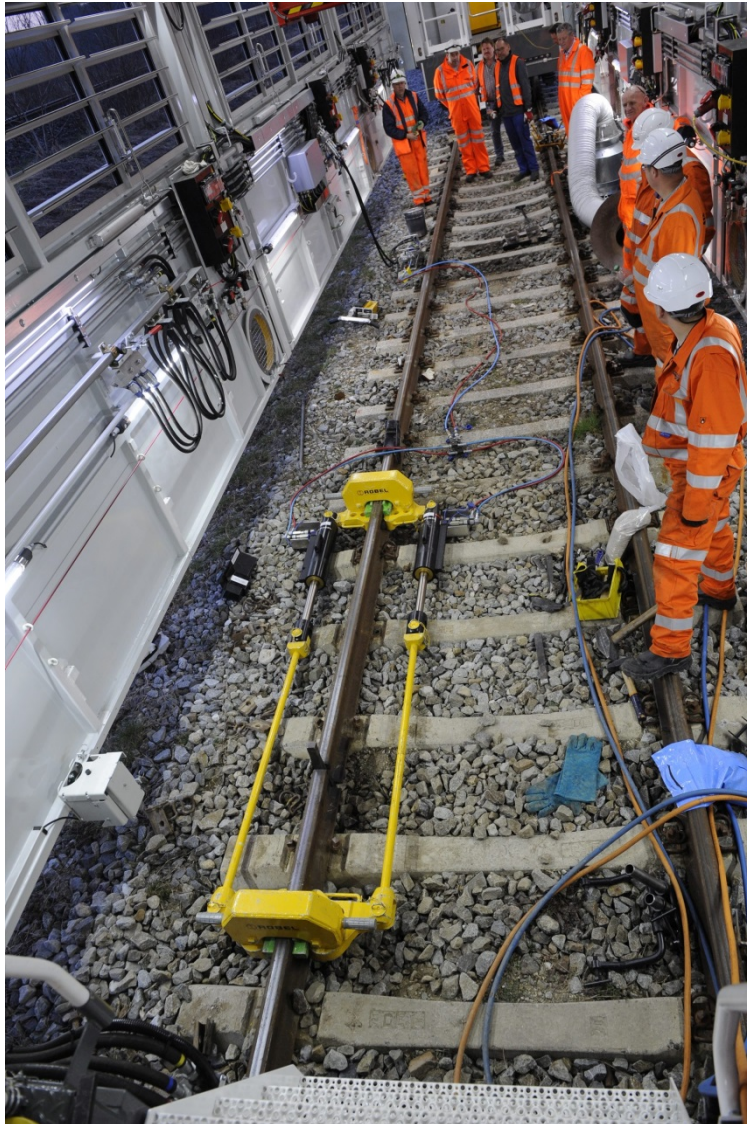

Fig. 7: The Mobile Maintenance Unit creates a protected, perfectly lit working area for replacing closure rails up to 15 m long with the use of hydraulically operated machines.

length of the train. Two hydraulic clamps at the end of the freely moving slewing arms guide the rails during loading and unloading. Cameras monitor the rear loading area, meaning that the operator controls all work processes from the cabin.

The two-sided **Chute Wagon Unit (CWU)** consists basically of two wagons with channels for rail positioning. Two rails at a time are deposited between or next to the track via spring-mounted chutes. During unloading the rails are unloaded by the rail manipulator, with universal roller heads preventing the rails from tipping over in narrow radii of up to 180 m and in superelevations.



Fig. 8: REX-S, consisting of chute wagon, transport unit and rail manipulator, can unload a pair of 180 m rails in two minutes and load it in four minutes.

Modified standard or container flat wagons with roller banks and rail clamps as well as two laterally mounted running rails for the manipulator form the **Transport Unit (TU)** for storage of up to 50 rails with a maximum length of 500 m in

several layers, depending on the clearance gauge (Fig. 9).

REX-S can unload a pair of 180 m rails in two minutes and load them in four minutes. This means that up to 2,700 m of rails are moved safely within an hour, adhering to



Fig. 9: Up to 50 rails with a maximum length of 500 m are transported safely, adhering to the bending limits and yield points.

deployable radii, bending limits and yield points, with rail replacement and transport of the old rails away from the work site performed in one work process.

6.1 Demonstrably consistent rail quality

When unloading long-welded rails the hydraulic clamps of the manipulator grab the rail ends, lift them and pull them forward. At the end of the train the rails are placed in the inclined channels on both sides of the CWU. The manipulator travels back a small distance, the arms grab the pair of rails again and push it off towards the track bed over the universal roller heads. At the same time a locomotive starts to pull out the train from under the rail. The RM moves in the opposite direction on its running rails at the same speed. As soon as there is sufficient momentum, the RM releases the rails and grabs the next pair.

This means that the rails are not pulled off unguided and with great effort, for instance with road-rail excavators, winch or rope, but glide onto the sleepers via the sprung end chutes within the stress limits. Furthermore, the universal roller heads prevent tilting during manipulation in narrow radii of up to 180 m as well as in superelevations which in turn does away with additional work. At no time are the yield and bending stresses exceeded, the rail remains brand new.

6.2 Pick-up and recycling

In the absence of suitable loading systems old rails are often cut into short pieces, loaded on trailers and brought to access points for transport via road or are just left lying around. A deposited rail can gradually creep forward longitudinally, especially in extreme temperature fluctuations. It gets wedged into obstacles, causes damage to the signalling technology and, in extreme cases, poses a risk for the open line. This is not only inefficient and expensive, but also takes away the possibility to gather old rails of good quality, recycle them and re-use them on branch lines.

The REX-S takes around four minutes to load a rail pair of 180 m in length, loading like unloading is performed within the bending limits and yield points, retaining the full usability of the rail. Furthermore, the system often will offer the only possibility for transporting long-welded rails from tracks that are difficult to access.

6.3 Safety and operator comfort

Human resources are an important lever for corporate decisions and investment. Work on the track has on the whole remained the same, but there are now more stringent requirements on safety and working conditions. Therefore, an attractive workplace is not only a prerequisite for motivated staff but a competitive advantage in recruiting a highly qualified workforce. With its focus on safety and ergonomics, the REX-S meets this requirement:

- Rail brakes prevent rails that have been unclamped from starting to move in gradients when they are grabbed by the manipulator.

- The RM grab arms have an automatic slew limiter.
- Cameras monitor the rear area of the loading train and provide full control of all work processes from the cabin.
- Proximity sensors in the seats prevent uncontrolled movements of the grab arms if the seat is unmanned.
- Sprung operator seats with adjustable seat height and position not only improve the ergonomic posture but also the view of the operator.
- The fully air-conditioned work area in the RM creates optimum conditions for consistently excellent performance.

6.4 Planning safety results in cost efficiency

The continuous high process speed of the rail train makes it possible to calculate the work cycle which forms the basis for precise work site planning. Only four people are required to ensure a consistently high unloading performance of the rail train. The precision of the work performed together with a significant reduction in working time and the reliability of the system are the facts that ultimately count for the network operators: cost reduction, profitability and fast return on investment.

7 The automation factor: the future of rail loading

The automated version of the REX-S Rail Train reduces manual work to a minimum. As a result, it is possible to operate the rail train with only three people - two in the manipulator and one on the chute wagon. Here, too, the safety aspect takes priority. The operator has no other choice than to adhere to safe processes and positions. There are no activities required on the transport unit. All processes on the unit are remote-controlled from a safe position next to the train. The operators no longer come into contact with the rails, which has been one of the main causes of severe accidents during rail loading.

Short set-up times and fast loading and unloading processes accelerate work with the rails and so shorten the line occupancy times. Time and cost of full track possessions no longer apply, adjacent tracks and overhead lines remain available throughout the work process.

7.1 The components of the automatic rail train

- The **hydraulic rail clamp** secures the rails with an automated clamping rack on the TU. Each rail is clamped individually at the web, without any securing damage to the rail head, as would often occur with common transport systems, e.g. from screwed clamps.
- **Roller banks with hydraulic cylinders** (Fig. 10) perform all slewing and locking processes on the TU. It is no longer necessary to endeavour the risky and time-

consuming walk on the wagons for manoeuvring the roller banks as all processes are now controlled remotely from a safe position, e.g. from within the manipulator. Thanks to a safe distance of the operator from the overhead line, it is no longer necessary to switch that off. The independent energy supply of each individual wagon increases operational safety and flexibility, the mechanical advantage from the hydraulic drive provides for full performance of the system, even in case of contaminations.

- The RM is equipped with **automatic front and rear accesses**; the treads remain horizontal in every position and thus ensure safe entry and exiting.

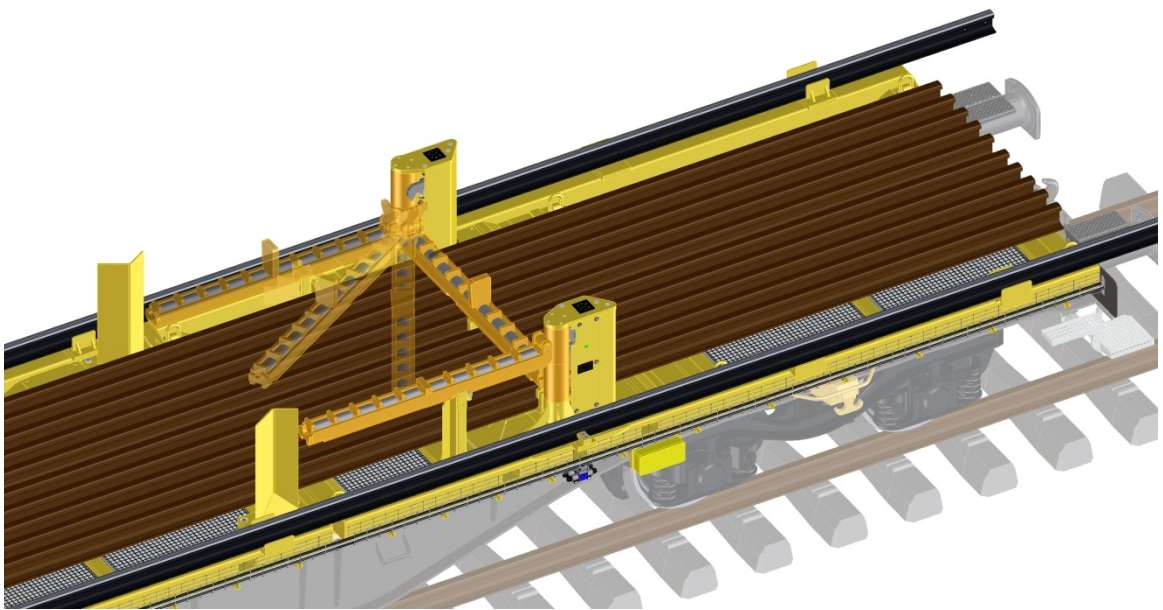

Fig. 10: Automated, slewable roller banks shorten the processing times and increase work safety: no more manual work on the transport unit.

7.2 Rail replacement on the Shinkansen

A significant step towards the future of urban maintenance is the extensive automation and synchronisation of the rail renewal process. The rail replacement system “REX-S 1200 Rail Exchange System” [4] for the Shinkansen network of JR East, developed and constructed by ROBEL in co-operation with Plasser & Theurer, offers a new solution.

The challenge of this project was to develop a process that combines rail replacement including welding and tensioning of new rails with the loading of old rails. In co-operation with Nippon Plasser, ROBEL and Plasser & Theurer developed a self-propelled rail loading system with an integrated flash butt welding facility and two specialist changeover wagons. With this combination of components from both companies a system was created that was customised to the customer’s requirements: REX-S renews 1,200 metres of track in only four hours.

In practice, the train works with a specially adapted PCU Power Car, a mobile welding robot APT-1500RA (Fig. 11), a transport unit, a rail manipulator and the self-propelled chute wagon with a rail positioning device. The system has capacity to carry a total of 20 x 150 m rails and achieves a speed of up to 70 km/h in self-propelled drive.



Fig. 11: The mobile APT welding robot from Plasser & Theurer is part of the REX-S 1200 Rail Exchange System used on the Shinkansen.

The work process starts with unloading the 150 m rails. The mobile welding robot is uncoupled from the chute wagon and the rail clamps on the transport unit are released. Now the rail manipulator transports the rails in pairs from the transport unit to the chute wagon and on next to the track bed where the mobile APT welding robot welds them together. While the welding takes place, the PCU Power Car together with the transport unit, chute wagon and rail manipulator continues unloading the remaining rails. After completing the unloading process the train is used to load the old rails from the previous night shift and to take them to the depot safely.

In the course of the second 4-hour shift the REX-S replaces the old rails with the new ones, using two on-track coupled changeover cars. The system takes about 30 minutes for exchanging a 1200 m pair of rails.

8 Summary

For maintenance companies the highly frequented infrastructure poses the challenge to carry out an ever increasing number of maintenance and renewal measures within ever shorter time windows. For rail replacement there is a clear direction: reduce the demand for resources, increase the flexibility and usability of the systems. The more modular the individual vehicles and machines are, the more efficient the construction company will

be. Which loading system gets used - the manually operated loading crane or the widely automated rail train - depends on the area of use and the task at hand: new construction or repair, targeted correction or complete rail replacement, underground tunnel, high-speed or high-load line. Within these conditions, factors such as rail quality, work safety and work result as well as time savings are essential indicators for the performance of the maintenance systems.

LITERATURE

- [1] Bauoffensive (Construction offensive): Deutsche Bahn/dpa, March 2017
- [2] Meißner, K., Wöhhart, A.: Schienenschweißen (Rail welding), Handbuch Eisenbahninfrastruktur, Lothar Fendrich, Wolfgang Fengler (eds.), March 2013, Springer Verlag
- [3] Marx, L., Bugenhagen, D., Moßmann, D.: Arbeitsverfahren für die Instandhaltung des Oberbaus (Work procedures for permanent way maintenance), DB Fachbuch, Eisenbahn-Fachverlag, 1991
- [4] Machatschek, R.: Schienenwechsel gegen die Zeit (Rail replacement in a race against time), in: Nahverkehr 5/2017, pp. 38-40
- [5] Brys, H.: Schienen effizient und sicher laden, transportieren und abladen (Loading, transporting and unloading rails efficiently and safely), EI Spezial Gleisbaumaschinen und Geräte, in EI 05/2016, pp. 40-43

IMAGE CREDITS

All images © ROBEL Bahnbaumaschinen GmbH



Bernhard Klee
Head of Rail Exchange System
ROBEL Bahnbaumaschinen GmbH, Freelancing
Bernhard.Klee@robел.info